



18 Frame Block-Style Stainless Steel Plunger Pump

**Standard
Model**

1861

**Flushed
Model**

1861K

FEATURES

- Triplex plunger design delivers high efficiency and low pulsation.
- Durable dual V-Packings are lubricated and cooled by pumped liquid.
- Pre-set Lo-Pressure Seals provide secondary protection against external leaks and require no packing adjustment.
- Special high-density, polished, concentric plungers provide a true wear surface and extended seal life.
- Specially formulated Seals and V-Packings offer unmatched performance and extended life.
- Wet-end easily serviced without entering crankcase.

SPECIFICATIONS

	U.S. Measure	Metric Measure
Flow	10.0 gpm	(38 l/m)
Pressure Range	100 to 3000 psi	(7 to 210 bar)
Inlet Pressure Range	+10 to 60 psi	(0.70 to 4 bar)
RPM	1429 rpm	(1429 rpm)
Bore.....	0.787"	(20 mm)
Stroke.....	1.181"	(30 mm)
Crankcase Capacity	42 oz.	(1.26 l)
Maximum Liquid Temperature	160°F	(71°C)
Above 130°F call CAT PUMPS for inlet conditions and elastomer recommendations.		
Inlet Ports (2)	1" NPTF	(1" NPTF)
Flushing Ports (2)*	1/4" NPTF	(1/4" NPTF)
Discharge Ports (2).....	1/2" NPTF	(1/2" NPTF)
Pulley Mounting.....	Either Side	(Either Side)
Shaft Diameter.....	1.181"	(30 mm)
Weight	67 lbs.	(30.4 kg)
Dimensions.....	18.37 x 12.99 x 6.49"	(466 x 330 x 165 mm)

* Flushed K Models: Special ported inlet manifold permits an external flush liquid providing cooling for hi-temp liquids and lubrication for low lubricity liquids.

ELECTRIC HORSEPOWER REQUIREMENTS

MODEL	FLOW		PRESSURE						MOTOR PULLEY SIZE	
			psi	psi	psi	psi	psi	psi	rpm	Pulley
	U.S. gpm	l/m	1500	1800	2000	2200	2500	3000	Using 1725 RPM Motor & Std. 10.0" Pump Pulley	O.D.
1861	10.0	38	10.3	12.4	13.7	15.1	17.2	20.5	1429	8.1
1861K	9.0	34	9.3	11.1	12.4	13.6	15.4	18.5	1286	7.3

DETERMINING THE PUMP R.P.M.	$\frac{\text{Rated gpm}}{\text{Rated rpm}}$	=	$\frac{\text{"Desired" gpm}}{\text{"Desired" rpm}}$
DETERMINING THE REQUIRED H.P.	$\frac{\text{gpm} \times \text{psi}}{1460}$	=	Electric Brake H. P. Required
DETERMINING MOTOR PULLEY SIZE	$\frac{\text{Motor Pulley O.D.}}{\text{Pump rpm}}$	=	$\frac{\text{Pump Pulley O.D.}}{\text{Motor rpm}}$

See complete Drive Packages [Includes: Pulleys, Belts, Hubs, Key] Tech Bulletin 003. Refer to pump **Service Manual** for repair procedure and additional technical information.

⚠ CAUTIONS AND WARNINGS

All High Pressure Systems require a primary pressure regulating device (i.e. regulator, unloader) and a secondary pressure relief device (i.e. pop-off valve, relief valve). Failure to install such relief devices could result in personal injury or damage to pump or property. CAT PUMPS does not assume any liability or responsibility for the operation of a customer's high pressure system.

Read all CAUTIONS and WARNINGS before commencing service or operation of any high pressure system. The CAUTIONS and WARNINGS are included in each service manual and with each Data sheet. CAUTIONS and WARNINGS can also be viewed online at www.catpumps.com/cautions-warnings or can be requested directly from CAT PUMPS.

WARRANTY

View the Limited Warranty on-line at www.catpumps.com/warranty.

"Customer confidence is our greatest asset"

PARTS LIST

ITEM	PART NUMBER		DESCRIPTION	QTY	
	1861	MATL			1861K
2	30067	STL	30067 STL	Key (M8x7.5x25)	1
5	92538	S	92538 S	Screw, HHC, Sems (M6x16)	8
8	43496	AL	43496 AL	Cover, Bearing	2
9	815281	FBR	815281 FBR	Shim, Split 2-Pc,	0/2
	814800	S	814800 S	Shim, Split 2-Pc	0/2
10	11340	NBR	11340 NBR	O-Ring, Bearing Cover - 70D	2
11	43495	NBR	43495 NBR	Seal, Oil, Crankshaft - 70D	2
15	39060	STL	39060 STL	Bearing, Roller	2
20	48600	TNM	48600 TNM	Rod, Connecting Assy [11/00]	3
25	43494	FCM	43494 FCM	Crankshaft, Dual End	1
31	828710	PE	828710 PE	Protector, Oil Cap w/Foam Gasket	1
32	43211	ABS	43211 ABS	Cap, Oil Filler	1
33	14177	NBR	14177 NBR	O-Ring, Filler Cap - 70D	1
37	92241	-	92241 -	Gauge, Oil, Bubble w/Gasket - 80D	1
38	44428	NBR	44428 NBR	Gasket, Flat, Oil Gauge - 80D	1
40	92542	S	92542 S	Screw, HHC, Sems (M6x20)	4
48	25625	STCP	25625 STCP	Plug, Drain (1/4"x19 BSP)	1
49	23170	NBR	23170 NBR	O-Ring, Drain Plug - 70D	1
50	43491	AL	43491 AL	Cover, Rear	1
51	44834	NBR	44834 NBR	O-Ring, Rear Cover - 70D	1
53	115471	AL	115471 AL	Crankcase w/Guide Pins	1
54	27488	S	27488 S	Pin, Guide	2
55	701268	SS	701268 SS	Stud, Manifold (M10x180)	4
64	43507	CM	43507 CM	Pin, Crosshead	3
65	48892	SSHB	48892 SSHB	Rod, Plunger [3/02]	3
69	126592	STCP R	126592 STCP R	Washer, Seal, Flat	3
70	43500	NBR	43500 NBR	Seal, Oil, Crankcase - 80D	3
75	43506	S	43506 S	Slinger, Barrier	3
88	45675	S	45675 S	Washer, Keyhole (M12)	3
89	45880	SS	45880 SS	Spacer, Collar	3
90	43300	CC	43300 CC	Plunger (M20x77)	3
95	89651	SS	89651 SS	Stud, Plunger Retainer (M6x70)	3
96	43235	PTFE	43235 PTFE	Back-up-Ring, Plunger Retainer	3
97	17399	NBR	17399 NBR	O-Ring, Plunger Retainer - 80D	3
	14160	FPM	14160 FPM	O-Ring, Plunger Retainer - 80D	3
	◆ 46204	EPDM	◆ 46204 EPDM	O-Ring, Plunger Retainer - 70D	3
	701715	IPFE	701715 IPFE	O-Ring, Plunger Retainer	3
98	44041	SS	44041 SS	Gasket, Plunger Retainer	3
99	44031	SS	44031 SS	Retainer, Plunger (M6)	3
100	43509	POP	43509 POP	Retainer, Seal	3
104	11379	NBR	11379 NBR	O-Ring, Inlet Adapter - 70D	3
	700134	FPM	700134 FPM	O-Ring, Inlet Adapter	3
	◆ 701491	EPDM	◆ 701491 EPDM	O-Ring, Inlet Adapter - 70D	3
	702705	IPFE	702705 IPFE	O-Ring, Inlet Adapter	3
105	701270	SS	701270 SS	Adapter, LPS	3
106	44071	NBR	44071 NBR	Seal, LPS w/SS-Spg	3
	44381	FPM	44381 FPM	Seal, LPS w/SS-Spg	3
	◆ 701974	SFTB*	◆ 701974 SFTB*	Seal, LPS w/SS-Spg	3
	703179	SFTA	703179 SFTA	Seal, LPS w/SS-Spg	3
110	701299	SS	-	Manifold, Inlet, Block-Style	1
	-	-	701309 SS	Manifold, Inlet, Block-Style, Flushed	1
111	701342	SS	701342 SS	Plug, Inlet (1"NPTM)	1
112	26969	NBR	26969 NBR	O-Ring, Spacer - 70D	15
	28459	FPM	28459 FPM	O-Ring, Spacer	15
	◆ 701863	EPDM	◆ 701863 EPDM	O-Ring, Spacer	15
	702028	IPFE	702028 IPFE	O-Ring, Spacer - 70D	15
113	28204	PTFE	28204 PTFE	Back-up-Ring, Spacer	12
114	701272	SS	701272 SS	Adapter, Valve, IMDM	6
118	701077	SS	-	Plug (1/4"NPTM)	3
122	43519	PTFE	43519 PTFE	Back-up-Ring, Spacer	3
123	13984	NBR	13984 NBR	O-Ring, Spacer- 70D	3
	14333	FPM	14333 FPM	O-Ring, Spacer	3
	◆ 701945	EPDM	◆ 701945 EPDM	O-Ring, Spacer	3
	703313	IPFE	703313 IPFE	O-Ring, Spacer	3
124	701271	SS	701271 SS	Cylinder, V-Packing	3
126	44164	SS	44164 SS	Adapter, Female	3
127	44607	STG*	44607 STG*	V-Packing	6
	44386	FPM	44386 FPM	V-Packing	6
128	44165	SS	44165 SS	Adapter, Male	3
162	43248	PTFE	43248 PTFE	Back-up-Ring, Seat	6
163	43249	NBR	43249 NBR	O-Ring, Seat - 80D	6
	44383	FPM	44383 FPM	O-Ring, Seat - 70D	6
	◆ 46206	EPDM	◆ 46206 EPDM	O-Ring, Seat - 70D	6

ITEM	PART NUMBER		DESCRIPTION	QTY	
	1861	MATL			1861K
	701852	IPFE	701852 IPFE	O-Ring, Seat	6
164	44037	SS	44037 SS	Seat	6
166	48793	SS	48793 SS	Valve	6
167	44039	SS	44039 SS	Spring, Valve	6
168	44564	PVDF	44564 PVDF	Retainer, Spring	6
179	701265	SS	701265 SS	Manifold, Valve Block, Block-Style	1
180	701078	SS	701078 SS	Plug (3/8"NPTM)	3
181	89628	S	89628 S	Screw, HSH (M12x65)	4
185	701300	SS	701300 SS	Manifold, Discharge, Block-Style	1
187	701269	SS	701269 SS	Stud, Manifold (M10x132)	4
191	19934	SS	19934 SS	Washer, Flat (M10)	8
192	15847	S	15847 S	Lockwasher (M10)	8
194	81258	S	81258 S	Nut (M10)	8
250	30764	NY	30764 NY	Protector, Shaft w/2 STCP Screws	1
	30764S	NY	30764S NY	Protector, Shaft w/2 SS Screws	1
255	30264	STZP	30264 STZP	Mount, Direct	1
260	30613	STZP R	30613 STZP R	Mount, Rail, Assy	1
265	30661	-	30661 -	Mounting, Assy (30613, 30206, 30059, 30067, 30764)	1
269	30206	F	30206 F	Pulley, 10.0" AB, [See Tech Bulletin 03]	1
274	30059	STL	30059 STL	Hub, H (M30) [See Tech Bulletin 03]	1
283	34334	-	34334 -	Kit, Oil Drain (3/8"x24") [See Tech Bulletin 077]	1
290	6124	-	6124 -	Gasket, Liquid (3 oz.)	1
299	901308	SS	-	Head, Complete, Block-Style	1
	-	-	901309 SS	Head, Complete, Block-Style, Flushed	1
300	701275	NBR*	701275 NBR*	Kit, Seal (Incls: 97,104,106, 112, 113,122,123,127)	1
	701809	FPM	701809 FPM	Kit, Seal (Incls: 97,104,106, 112,113,122,123,127)	1
	◆ 701808	EPDM*	◆ 701808 EPDM*	Kit, Seal (Incls: 97,104,106, 112,113,122,123,127)	1
	76175	IPFE	76175 IPFE	Kit, Seal (Incls: 97,104,106, 112,113,122,123,127)	1
310	701695	NBR	701695 NBR	Kit, Valve (Incls: 112,113,162, 163,164,166,167,168)	2
	701434	FPM	701434 FPM	Kit, Valve (Incls: 112,113,162, 163,164,166,167,168)	2
	◆ 701804	EPDM	◆ 701804 EPDM	Kit, Valve (Incls: 112,113,162, 163, 164,166,167,168)	2
	76695	IPFE	76695 IPFE	Kit, Valve (Incls: 112,113,162, 163, 164,166,167,168)	2
350	30696	STZP	30696 STZP	Plier, Reverse	1
370	-	-	990663 -	Assembly, Flushing, 5 gal, 115V, 1.1Amp, 1/2" NPT	1
390	^ 711500	SS	^ 711500 SS	C.A.T. (Inlet pressure stabilizer for RO and boosted inlet applications)	1
391	^ 711504	SS	^ 711504 SS	Adapter (2 per C.A.T.) (See Data Sheet for complete selection)	2
392	^ 701818	SS	^ 701818 SS	Elbow Assy used with Adapter Assy 711504	1
-	6107	-	6107 -	Oil Bottles 21 oz. ISO 68 Hydraulic (Fill to specified crankcase capacity prior to start-up)	2
-	6119	-	6119 -	Lubricant, Antiseize (1 oz) (See Tech Bulletin 095)	1

Bold print part numbers are unique to a particular pump model.

Italics are optional items.

◆ Silicone oil/grease required.

R Components comply with RoHS Directive.

[] Date of latest production change.

* Review individual parts in each kit for material code identification

^ **C.A.T. highly recommended for pressurized inlet, R.O. and Industrial applications.**

View Tech Bulletins 002, 003, 024, 035, 036, 043, 074, 077, 083, 089 and 095 for additional information.

MATERIAL CODES (Not Part of Part Number): ABS=ABS Plastic AL=Aluminum CC=Ceramic CM=Chrome-Moly EPDM=Ethylene Propylene Diene Monomer F=Cast Iron FBR=Fiber FCM=Forged Chrome-Moly FPM=Fluorocarbon NBR=Medium Nitrile (Buna-N) NY=Nylon PE=Polyethylene POP=Polypropylene PTFE=Pure Polytetrafluoroethylene PVDF=Polyvinylidene Fluoride S=304SS SFTB=Special Blend PTFE Black SS=316SS SSHB=316SS w/High Strength Brass STCP=Steel/Chrome Plated STG=Special Blend PTFE White STL=Steel STZP=Steel/Zinc Plated TNM=Special High Strength

EXPLODED VIEW

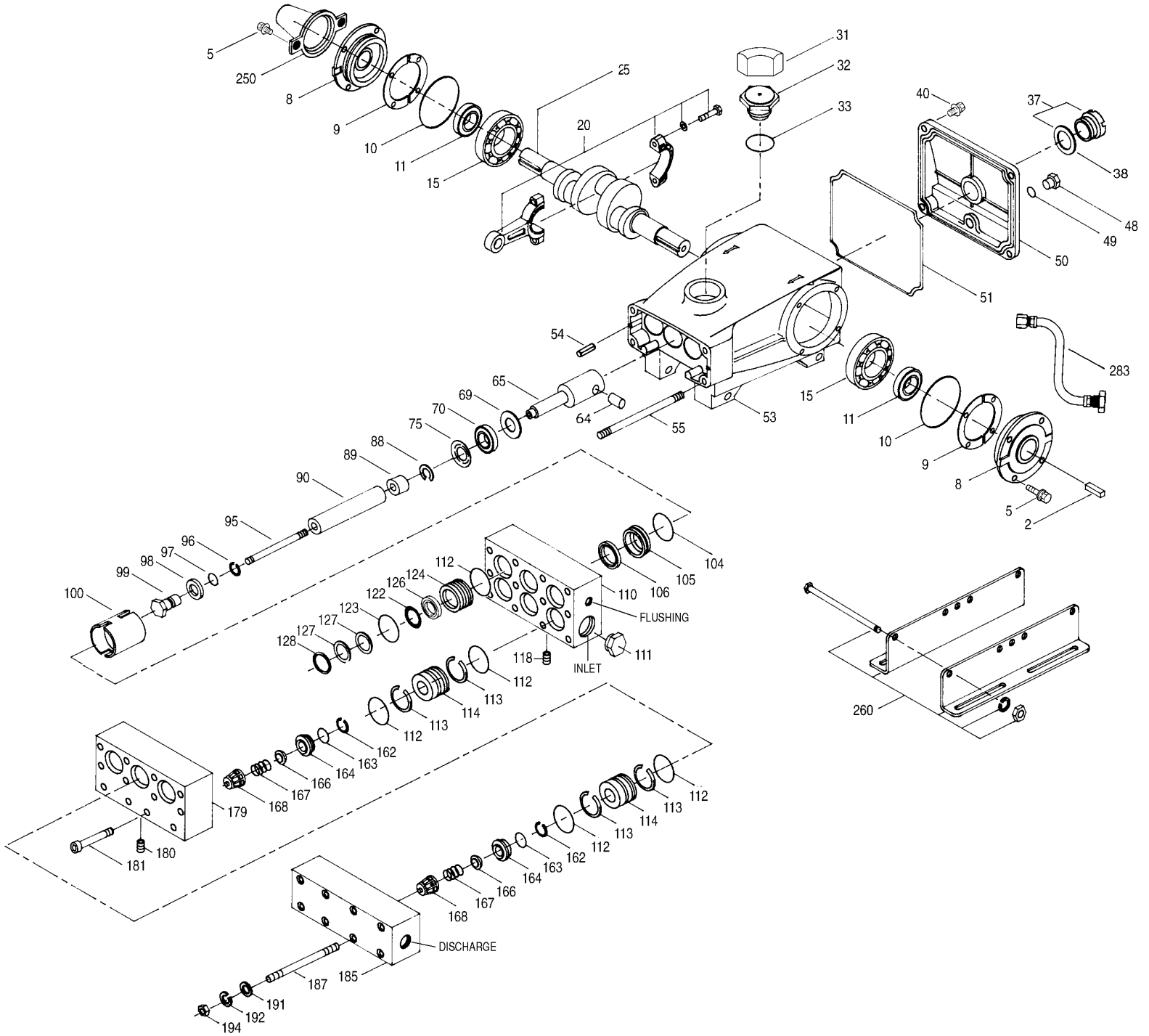

Models
 Standard - 1861
 Flushed - 1861K
 July 2010

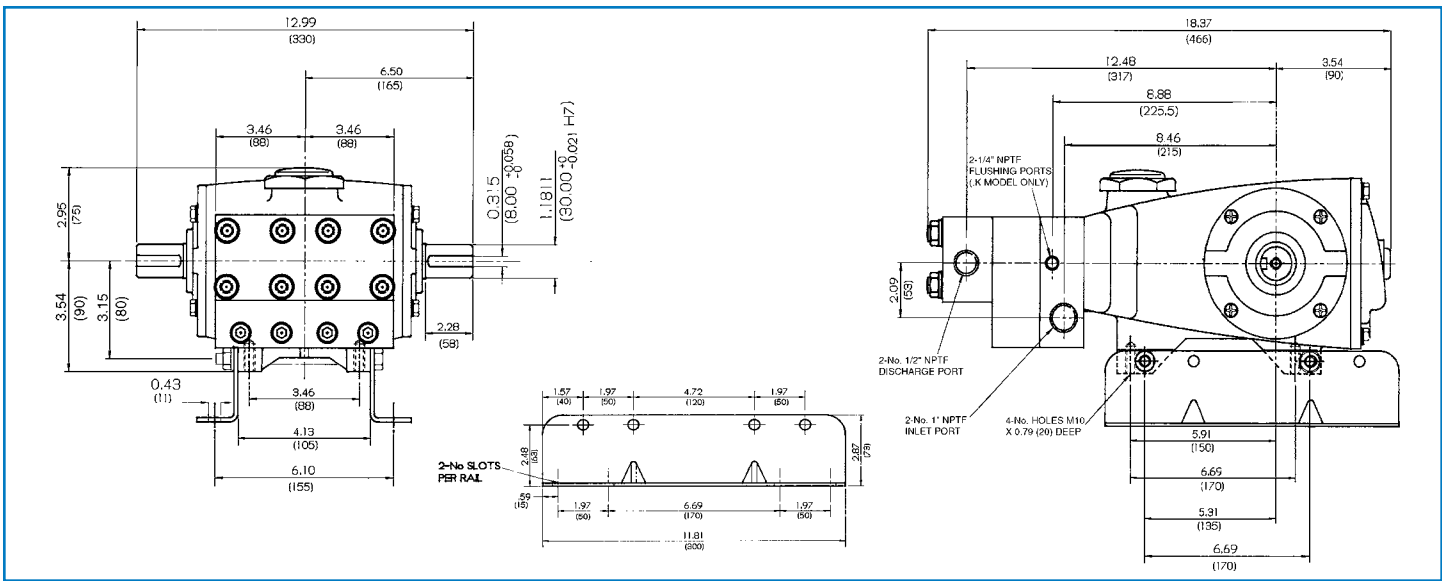

Models 1861 and 1861K

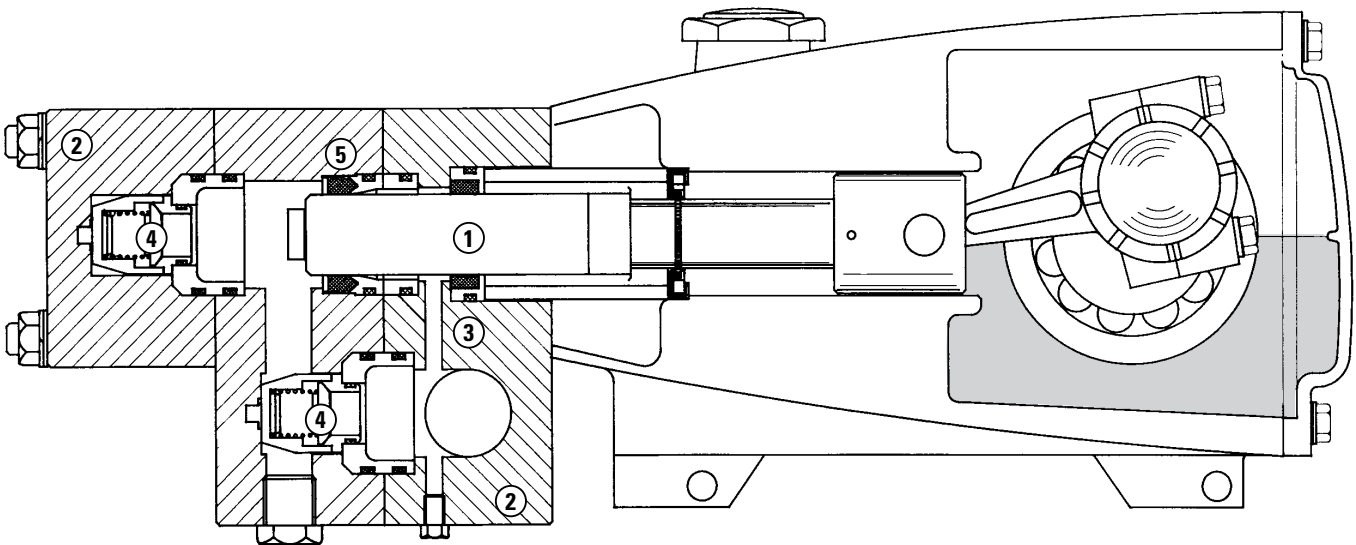

- 1 Special concentric, high-density, polished, solid ceramic **plungers** provide a true wear surface and extended seal life.
- 2 **Manifolds** are 316 SS block-style for long term continuous duty and corrosion resistance.
- 3 **Standard Models:** Lo-Pressure Seals and V-Packings are completely lubricated and cooled by the liquid being pumped.
Flushed Models: Optional special ported Flushed Inlet Manifold permits external flush for lubricating and cooling seals when pumping liquids such as DI water, Hi-Temp or low lubricity.
- 4 Stainless steel **valves, seats and springs** provide corrosion-resistance, ultimate seating and extended life.
- 5 Specially formulated, CAT PUMP exclusive, **V-Packings** offer unmatched performance and seal life.

World Headquarters

CAT PUMPS

1681 - 94th Lane N.E. Minneapolis, MN 55449-4324

Phone (763) 780-5440 — FAX (763) 780-2958

e-mail: techsupport@catpumps.com

www.catpumps.com

International Inquiries

FAX (763) 785-4329

e-mail: intlsales@catpumps.com



The Pumps with Nine Lives

CAT PUMPS (U.K.) LTD.

1 Fleet Business Park, Sandy Lane, Church Crookham

FLEET, Hampshire GU52 8BF, England

Phone Fleet 44 1252-622031 — Fax 44 1252-626655

e-mail: sales@catpumps.co.uk www.catpumps.co.uk

N.V. CAT PUMPS INTERNATIONAL S.A.

Heiveldekens 6A, 2550 Kontich, Belgium

Phone 32-3-450.71.50 — Fax 32-3-450.71.51

e-mail: cpi@catpumps.be www.catpumps.be

CAT PUMPS DEUTSCHLAND GmbH

Buchwiese 2, D-65510 Idstein, Germany

Phone 49 6126-9303 0 — Fax 49 6126-9303 33

e-mail: catpumps@t-online.de www.catpumps.de