

## 38 Frame Block-Style Stainless Steel Plunger Pump

**Standard Models** 3821, 3831

**Flushed Models** 3821K, 3831K

### FEATURES

#### Superior Design

- Triplex plunger design provides smoother liquid flow.
- Oil bath crankcase assures optimum lubrication.
- Close tolerance concentricity of the ceramic plunger maximizes seal life.
- **Standard Models:** Lo-Pressure Seals and V-Packings are completely lubricated and cooled by the liquid being pumped.
- **K Models:** Special Flushed Inlet Manifold permits flush for added cooling with high temperature liquids and lubrication with low lubricity liquids.

#### Quality Materials

- Precision design 316 stainless steel valves are hardened and polished for ultimate seating and extended valve life.
- 316 SSL block-style manifolds for strength and corrosion resistance.
- Special concentric, high-density, polished, solid ceramic plungers provide a true wear surface and extended seal life.
- Specially formulated, CAT PUMP exclusive, V-Packings offers unmatched performance and seal life.
- Die cast aluminum crankcase provides high strength, minimum weight and precision tolerance control.
- Optional Cast Iron crankcase for hazardous environments.
- Chrome-moly crankshaft gives unmatched strength and surface hardness.
- Oversized crankshaft bearings with greater loading capacity means longer bearing life.

#### Easy Maintenance

- Wet-end is easily serviced without entering crankcase, requiring less time and effort.
- Inlet and discharge valve assemblies interchange for easier maintenance without disturbing piping.
- Preset packings mean no packing gland adjustment is necessary, reducing maintenance costs.

#### **⚠ WARNING**

All systems require both a primary pressure regulating device (i.e., regulator, unloader) and a secondary pressure safety relief device (i.e., pop-off valve, safety valve). Failure to install such relief devices could result in personal injury or damage to the pump or to system components. CAT PUMPS does not assume any liability or responsibility for the operation of a customer's high pressure system.

### SPECIFICATIONS

U.S. Measure      Metric Measure

#### MODEL 3821, 3821K

Flow.....23 GPM (87 L/M)  
Pressure Range.....100 to 2000 PSI (7 to 140 BAR)  
Bore.....1.260" (32 mm)

#### MODEL 3831, 3831K

Flow.....36 GPM (136 L/M)  
Pressure Range.....100 to 1200 PSI (7 to 85 BAR)  
Bore.....1.575" (40 mm)

#### COMMON SPECIFICATIONS

Inlet Pressure\*.....Flooded to 70 PSI (Flooded to 4.9 BAR)  
RPM .....800 RPM (800 RPM)  
Stroke.....1.890" (48 mm)  
Crankcase Capacity.....4.2 Qts. (4 L)  
Maximum Liquid Temperature .....160°F (71°C)

Above 130°F call CAT PUMPS for inlet conditions and elastomer recommendations.

Inlet Ports (2).....1-1/2" NPTF (1-1/2" NPTF)  
Flushing Ports (2)\*.....1/2" NPTF (1/2" NPTF)  
Discharge Ports (2).....1" NPTF (1" NPTF)  
Pulley Mounting .....Either Side (Either Side)  
Shaft Diameter .....1.378" (35 mm)  
Weight.....167 lbs. (75 kg)  
Dimensions.....24.4 x 18.11 x 9.37" (620 x 460 x 238 mm)

\* K Models: Special Flushed Inlet Manifold permits external flush for added cooling with high temperature liquids and lubrication with low lubricity liquids.

### ELECTRIC HORSEPOWER REQUIREMENTS

MODEL	FLOW		PRESSURE						RPM
	U.S. GPM	L/M	PSI 800	PSI 1000	PSI 1200	PSI 1500	PSI 1800	PSI 2000	
			BAR 55	BAR 70	BAR 85	BAR 105	BAR 125	BAR 140	
<b>3821</b>	23	87	N/A	N/A	N/A	23.7	28.4	31.6	800
<b>3821K</b>	20	76	N/A	N/A	N/A	20.6	24.7	27.4	696
	18	68	N/A	N/A	N/A	18.5	22.2	24.7	626
<b>3831</b>	36	136	19.8	24.7	29.7	N/A	N/A	N/A	800
<b>3831K</b>	30	114	16.5	20.6	24.7	N/A	N/A	N/A	667
	25	95	13.7	17.2	20.6	N/A	N/A	N/A	556

**DETERMINING THE PUMP R.P.M.**       $\frac{\text{Rated G.P.M.}}{\text{Rated R.P.M.}}$  =  $\frac{\text{"Desired" G.P.M.}}{\text{"Desired" R.P.M.}}$

**DETERMINING THE REQUIRED H.P.**       $\frac{\text{GPM x PSI}}{1460}$  = Electric Brake H. P. Required

**DETERMINING MOTOR PULLEY SIZE**       $\frac{\text{Motor Pulley O.D.}}{\text{Pump R.P.M.}}$  =  $\frac{\text{Pump Pulley O.D.}}{\text{Motor R.P.M.}}$

See complete Drive Packages [Inclds: Pulleys, Belts, Hubs, Key] Tech Bulletin 003. Refer to pump **Service Manual** for repair procedure, additional technical information and **pump warranty**.

*"Customer confidence is our greatest asset"*



# EXPLODED VIEW

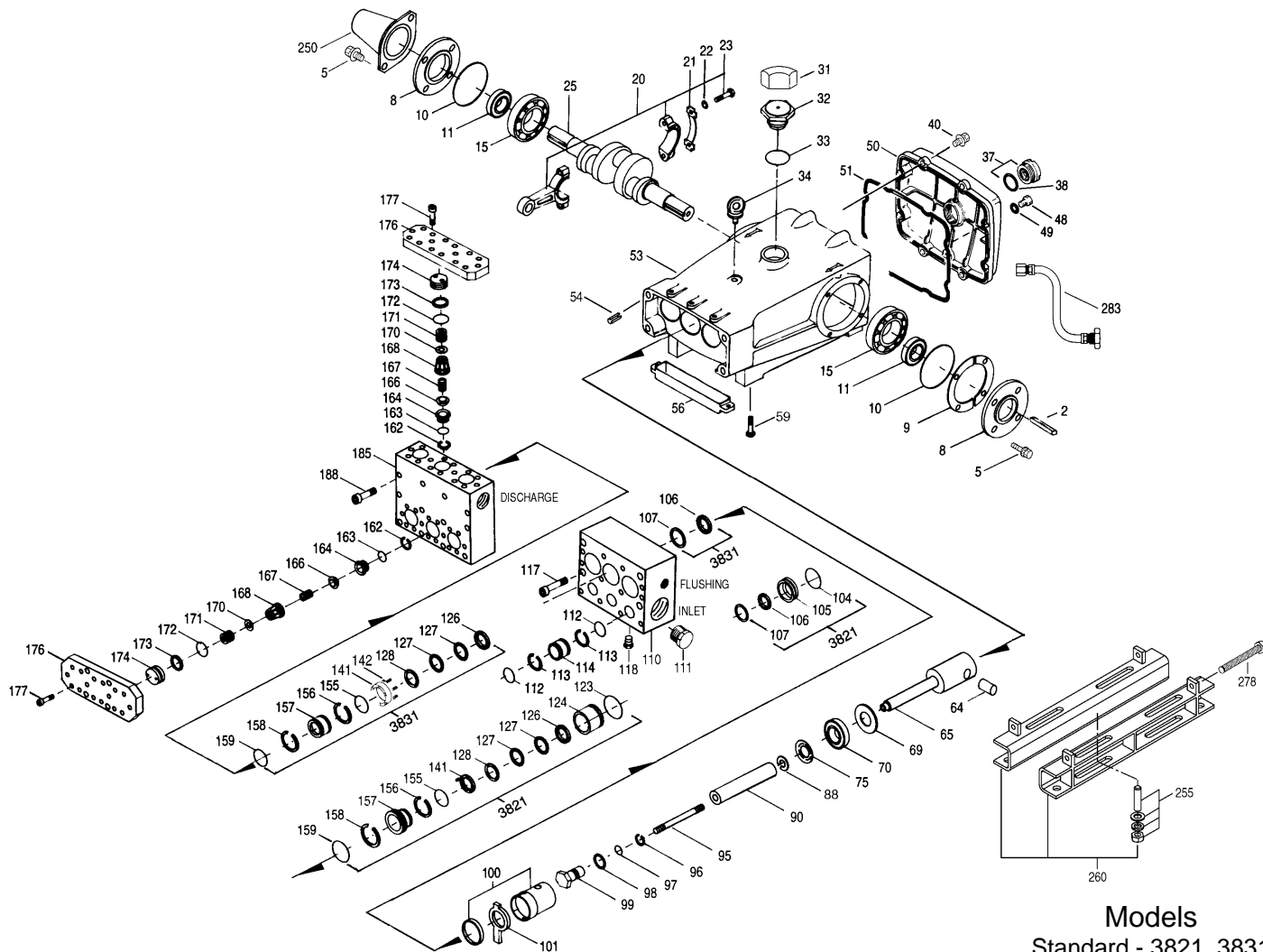

Models  
Standard - 3821, 3831  
Flushed - 3821K, 3831K  
February 2009

	<b>3821</b>	<b>MATL</b>	<b>3821K</b>	<b>MATL</b>	<b>3831</b>	<b>MATL</b>	<b>3831K</b>	<b>MATL</b>		
174	701278	SS	701278	SS	701278	SS	701278	SS	Plug, Valve	6
176	701316	SS	701316	SS	701316	SS	701316	SS	Cover, Valve	2
177	87951	S	87951	S	87951	S	87951	S	Screw, HSH (M10x30)	32
185	701315	SSL	701315	SSL	701315	SSL	701315	SSL	Manifold, Discharge, Block-Style	1
188	701279	S	701279	S	701279	S	701279	S	Screw, HSH (M12x100)	12
196	701342	SS	701342	SS	701342	SS	701342	SS	Plug, Discharge (1" NPT) Not Shown	1
250	44516	NY	44516	NY	44516	NY	44516	NY	Protector, Shaft w/2 Screws, Lockwashers and Washers (Incl w/Pump)	1
255	34039	S	34039	S	34039	S	34039	S	Assy, Direct Mount	1
260	92674	STZP	92674	STZP	92674	STZP	92674	STZP	Mount, Rail Assy (Incls: 34018)	1
275	990013	STL	990013	STL	990013	STL	990013	STL	Hub, "B", (35mm Keyway) <b>[See Drive Packages Tech 003]</b>	1
278	80540	ZP	80540	ZP	80540	ZP	80540	ZP	Screw, HH (M12x100) (Rail Adjusting Screw)	1
279	30278	STZP	30278	STZP	30278	STZP	30278	STZP	Oiler (1 oz.) Not Shown	3
281	30967	—	30967	—	30967	—	30967	—	Glass, Oiler Not Shown	3
282	10069	NBR	10069	NBR	10069	NBR	10069	NBR	Gasket, Oiler Not Shown	3
283	34314	—	34314	—	34314	—	34314	—	Kit, Oil Drain (3/8" X 48")	1
290	6124	—	6124	—	6124	—	6124	—	Gasket, Liquid (3 oz.)	1
299	<b>901401</b>	<b>SSL</b>	—	—	<b>901400</b>	<b>SSL</b>	—	—	Head, Complete, Block-Style	1
	—	—	<b>901405</b>	<b>SSL</b>	—	—	<b>901404</b>	<b>SSL</b>	Head, Complete, Block-Style, Flushed	1
300	<b>701699</b>	<b>NBR</b>	<b>701699</b>	<b>NBR</b>	<b>701698</b>	<b>NBR</b>	<b>701698</b>	<b>NBR</b>	Kit, Seal (Incls: 97,104,106,112,113,123,127,155,156,158,159)	1
	<b>33269</b>	<b>FPM</b>	<b>33269</b>	<b>FPM</b>	<b>33268</b>	<b>FPM</b>	<b>33268</b>	<b>FPM</b>	Kit, Seal (Incls: 97,104,106,112,113,123,127,155,156,158,159)	1
	<b>701714</b>	<b>EPDM</b>	<b>701714</b>	<b>EPDM</b>	<b>701797</b>	<b>EPDM</b>	<b>701797</b>	<b>EPDM</b>	Kit, Seal (Incls: 97,104,106,112,113,123,127,155,156,158,159)	1
310	34017	NBR	34017	NBR	34017	NBR	34017	NBR	Kit, Valve, Preassembled (Incls: 162,163,164,166,167,168,170,172,173)	2
	31955	FPM	31955	FPM	31955	FPM	31955	FPM	Kit, Valve, Preassembled (Incls: 162,163,164,166,167,168,170,172,173)	2
	<b>31952</b>	<b>EPDM</b>	<b>31952</b>	<b>EPDM</b>	<b>31952</b>	<b>EPDM</b>	<b>31952</b>	<b>EPDM</b>	Kit, Valve, Preassembled (Incls: 162,163,164,166,167,168,170,172,173)	2
	819000	F	819000	F	819000	F	819000	F	Assembly, Crankcase, Cast Iron Conversion	1
370	—	—	<b>990663</b>	—	—	—	<b>990663</b>	—	Assembly, Flushing, 5 gal., 115V, 1.1 Amp, 1/2"NPT	1
390	714500	SS	714500	SS	714500	SS	714500	SS	C.A.T. (Inlet pressure stabilizer for RO and boosted inlet applications)	1
391	714506	SS	714506	SS	714506	SS	714506	SS	Adapter (2 per C.A.T.) (See Data Sheet for complete selection)	2
392	701828	SS	701828	SS	701828	SS	701828	SS	Elbow Assy used with Adapter Assy 714506	1
	6100	—	6100	—	6100	—	6100	—	Oil, Case (12-21 oz. Bottles) ISO-68 Hydraulic (Fill to specified crankcase capacity prior to start-up)	1

**Bold print part numbers are unique to a particular pump model. Italics are optional items.** [ ] Date of latest production change. ♦ Silicone oil/grease required.

† Production parts are different than replacement parts. R Components comply with RoHS Directive. \* Review individual parts in each kit for material code identification.

See Tech Bulletins 002, 003, 024, 035, 036, 041, 043, 053, 074, 077, 083, 095 and 105 for additional information. **C.A.T. highly recommended for pressurized inlet, R.O. and industrial applications.**

MATERIAL CODES (Not Part of Part Number): ABS=ABS Plastic AL=Aluminum CC=Ceramic CM=Chrome-Moly D=Acetal EPDM=Ethylene Propylene Diene Monomer F=Cast Iron FBR=Fiber

FCM=Forged Chrome-moly FPM=Fluorocarbon NBR=Medium Nitrile (Buna-N) NBRs=Buna, Silicone Free NY=Nylon POP=Polypropylene PTFE=Pure Polytetrafluoroethylene

PVDF=Polyvinylidene Fluoride S=304SS SFG=Special Blend FPM SS=316SS SSL=316SS/Low Carbon SSZZ=316SS/Zamak STG=Special Blend PTFE White STL=Steel

STZP=Steel/Zinc Plated TNM=Special High Strength ZP=Zinc Plated

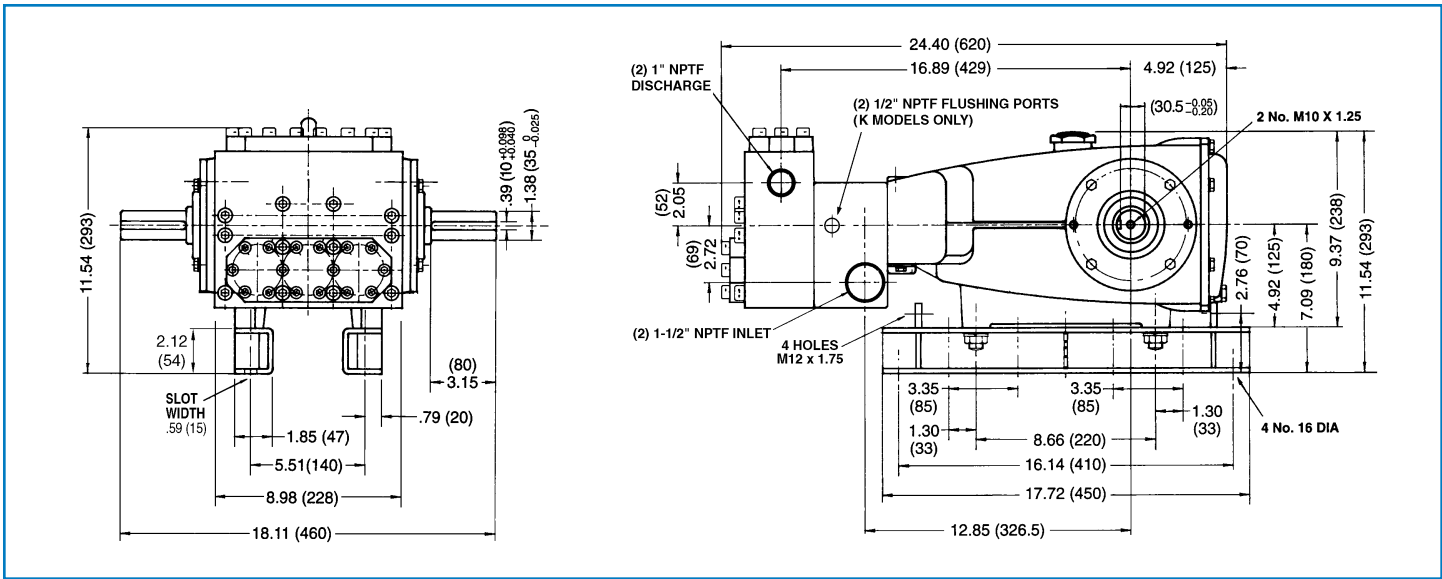

Models 3821, 3821K, 3831, 3831K

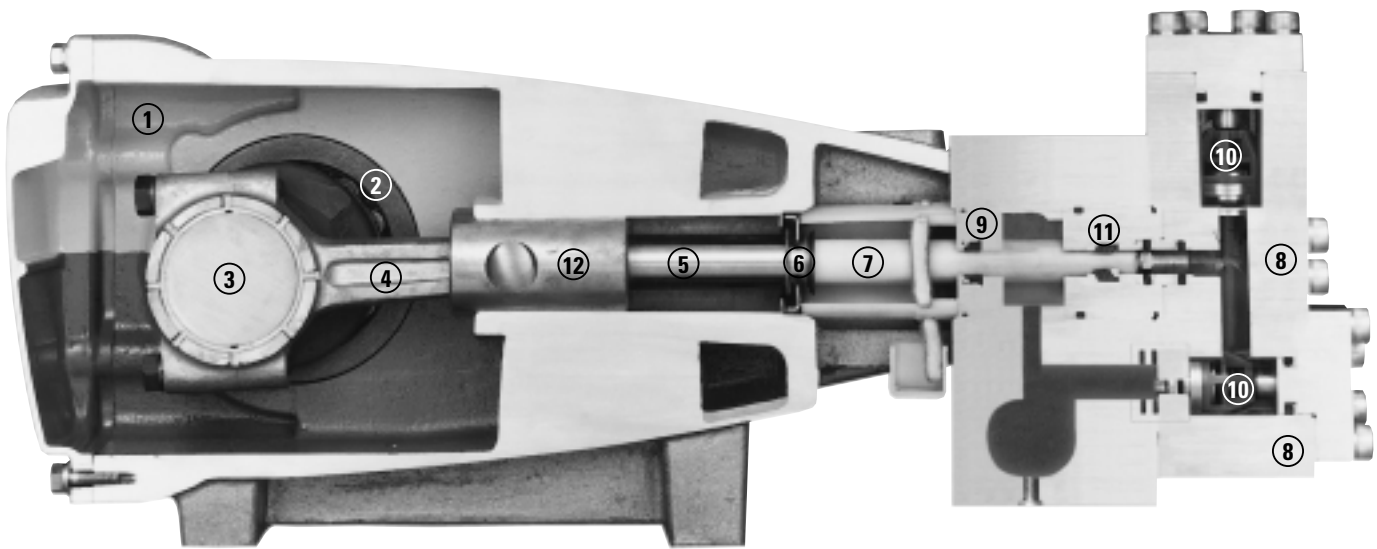

- 1 Die cast aluminum **crankcase** means high strength, lightweight, and excellent tolerance control.
- 2 Oversized crankshaft **bearings** provide extended bearing life and pump performance.
- 3 Chrome-moly **crankshaft** provides unmatched strength and surface hardness for long life.
- 4 Matched oversized high strength TNM **connecting rods** noted for superior strength and bearing quality.
- 5 Special stainless steel **plunger rods** with high strength crossheads for longevity and corrosion resistance.
- 6 The stainless steel **slinger** provides back-up protection for the crankcase seal, keeping pumped liquids out of the crankcase.
- 7 Special concentric, high-density, polished, solid ceramic **plungers** provide a true wear surface and extended seal life.
- 8 **Manifolds** are 316 SSL block-style for long-term continuous-duty and corrosion resistance.
- 9 **Standard Models:** Lo Pressure Seals and V-Packings are completely lubricated and cooled by the liquid being pumped.
- 9 Special **Flushed Inlet Manifold** permits external flush for added cooling with high temperature liquids and lubrication with low lubricity liquids.
- 10 Stainless steel **valves, seats and springs** provide corrosion-resistance, ultimate seating and extended life.
- 11 Specially formulated, CAT PUMP exclusive, **V-Packings** offer unmatched performance and seal life.
- 12 **Crossheads** are 360° supported for uncompromising alignment.

**World Headquarters**  
**CAT PUMPS**  
 1681 - 94th Lane N.E. Minneapolis, MN 55449-4324  
 Phone (763) 780-5440 — FAX (763) 780-2958  
 e-mail: techsupport@catpumps.com  
 www.catpumps.com

**International Inquiries**  
 FAX (763) 785-4329  
 e-mail: intlsales@catpumps.com



**CAT PUMPS (U.K.) LTD.**  
 1 Fleet Business Park, Sandy Lane, Church Crookham  
 FLEET, Hampshire, GU52 8BF, England  
 Phone Fleet 44 1252-622031 — Fax 44 1252-626655  
 e-mail: sales@catpumps.co.uk www.catpumps.co.uk

**N.V. CAT PUMPS INTERNATIONAL S.A.**  
 Heiveldekens 6A, B-2550 Kontich, Belgium  
 Phone 32-3-450.71.50 — Fax 32-3-450.71.51  
 e-mail: cpi@catpumps.be www.catpumps.be

**CAT PUMPS DEUTSCHLAND GmbH**  
 Buchwiese 2, D-65510 Idstein, Germany  
 Phone 49 6126-9303 0 — Fax 49 6126-9303 33  
 e-mail: catpumps@t-online.de www.catpumps.de