

15 Frame Plunger Pump

**Standard Brass
Model**

650

FEATURES

- Triplex design delivers high efficiency and low pulsation.
- Durable V-Packings are lubricated and cooled by the liquid being pumped.
- Pre-set Lo-Pressure Seals provide secondary protection against external leaks and require no packing adjustment.
- Special high-density, polished, concentric plungers provide a true wear surface and extended seal life.

SPECIFICATIONS

	U.S. Measure	Metric Measure
Flow.....	7.0 gpm	(27 lpm)
Pressure Range.....	100 to 3000 psi	(7 to 210 bar)
RPM.....	1000 rpm	(1000 rpm)
Inlet Pressure Range.....	-5 to +60 psi	(-0.35 to +4 bar)
Bore.....	.787"	(20 mm)
Stroke.....	1.181"	(30 mm)
Crankcase Capacity.....	42 oz.	(1.26 l)
Maximum Liquid Temperature.....	160°F	(71°C)
Above 130F call Cat Pumps for inlet conditions and elastomer recommendations.		
Inlet Ports (2).....	3/4" NPTF	(3/4" NPTF)
Discharge Ports (2).....	1/2" NPTF	(1/2" NPTF)
Pulley Mounting.....	Either Side	(Either Side)
Shaft Diameter.....	1.181"	(30 mm)
Weight.....	44 lbs.	(19.9 kg)
Dimensions.....	16.28x12.99x6.44"	(413.50x330x163.50 mm)

ELECTRIC HORSEPOWER REQUIREMENTS

FLOW		PRESSURE			MOTOR PULLEY SIZE	
		psi 2000	psi 2500	psi 3000	Using 1725 rpm Motor 10" O.D. Pump Pulley	
U.S. gpm	lpm	bar 140	bar 175	bar 210	rpm	Pulley O.D.
7.0	27	9.6	12.0	14.4	1000	5.7
6.0	23	8.2	10.3	12.4	858	4.9
5.0	19	6.9	8.6	10.3	715	4.1

⚠ CAUTIONS AND WARNINGS

All High Pressure Systems require a primary pressure regulating device (i.e. regulator, unloader) and a secondary pressure relief device (i.e. pop-off valve, relief valve). Failure to install such relief devices could result in personal injury or damage to pump or property. CAT PUMPS does not assume any liability or responsibility for the operation of a customer's high pressure system.

Read all CAUTIONS and WARNINGS before commencing service or operation of any high pressure system. The CAUTIONS and WARNINGS are included in each service manual and with each Accessory Data sheet. CAUTIONS and WARNINGS can also be viewed online at www.catpumps.com/cautions-warnings or can be requested directly from CAT PUMPS.

WARRANTY

View the Limited Warranty on-line at www.catpumps.com/warranty.

DETERMINING THE PUMP R.P.M.	Rated gpm	=	"Desired" gpm
	Rated rpm	=	"Desired" rpm
DETERMINING THE REQUIRED H.P.	gpm x psi	=	Electric Brake
	1460	=	H. P. Required
DETERMINING MOTOR PULLEY SIZE	Motor Pulley O.D.	=	Pump Pulley O.D.
	Pump rpm	=	Motor rpm

See complete Drive Packages [Incls: Pulleys, Belts, Hubs, Key] Tech Bulletin 003.
Refer to pump **Service Manual** for repair procedure and additional technical information.

PARTS LIST

ITEM	PART NUMBER	MATL	DESCRIPTION	QTY
2	30067	STL	Key (M8x7.5x25)	1
5	92519	STZP	Screw, HHC (M6x16)	8
8	43496	AL	Cover, Bearing	2
9	815281	FBR	Split Shim, Bearing Cover, 2 Pc.	2
10	11340	NBR	O-Ring, Bearing Case - 70D	2
11	43495	NBR	Seal, Oil, Crankshaft - 70D	2
15	39060	STL	Bearing, Roller	2
20	48600	TNM	Rod Assy, Connecting [11/00]	3
25	43494	FCM	Crankshaft - Dual End	1
31	828710	PE	Protector, Oil Cap w/Foam Gasket	1
32	43211	ABS	Cap, Oil Filler	1
33	14177	NBR	O-Ring, Filler Cap - 70D	1
37	92241	—	Gauge, Oil, Bubble w/Gasket - 80D	1
38	44428	NBR	Gasket, Flat, Oil Gauge - 80D	1
40	92520	STZP	Screw, Sems HHC (M6x20)	4
48	25625	STCP	Plug, Drain (1/4"x19BSP)	1
49	23170	NBR	O-Ring, Drain Plug - 70D	1
50	43491	AL	Cover, Rear	1
51	44834	NBR	O-Ring, Rear Cover - 70D	1
53	115471	AL	Crankcase w/Guide Pins	1
54	27488	S	Pin, Guide	2
56	44664	POP	Pan, Oil	1
64	43507	CM	Pin, Crosshead	3
65	43501	SZZ	Rod, Plunger	3
69	126592	STCP R	Washer, Seal	3
70	43500	NBR	Seal, Oil, Crankcase - 80D	3
75	43506	S	Slinger, Barrier	3
88	45675	S	Washer, Keyhole	3
89	43505	BB	Spacer, Plunger	3
90	43300	CC	Plunger (M20x77)	3
96	43235	PTFE	Back-up-Ring, Plunger Retainer	3
97	17399	NBR	O-Ring, Plunger Retainer - 80D	3
	14160	FPM	O-Ring, Plunger Retainer - 80D	3
	◆ 46204	EPDM	O-Ring, Plunger Retainer - 70D	3
98	45891	CU	Gasket, Plunger Retainer	3
99	104360	S	Retainer w/stud, Plunger (M5)	3
100	855001	POP	Retainer, Seal (See Tech Bulletin 098)	3
101	43508	—	Wick, Long Tab	3
106	44071	NBR	Seal, LPS w/SS-Spg	3
	44381	FPM	Seal, LPS w/S-Spg	3
	701974	SFTB	Seal, LPS w/NIH-Spg	3
120	49291	BB	Case, Seal [07/05]	3
121	14762	NBR	O-Ring, Seal Case - 70D	3
	11737	FPM	O-Ring, Seal Case - 75D	3
	◆ 46205	EPDM	O-Ring, Seal Case	3
126	43515	BB	Adapter, Female [01/04]	3
127	44607	STG	V-Packing	6
	44386	FPM	V-Packing	6
128	43517	BB	Adapter, Male	3
139	20326	BBCP	Plug, Inlet (3/4" NPT)	1
162	43248	PTFE	Back-up-Ring, Seat	6
163	43249	NBR	O-Ring, Seat - 80D	6
	44383	FPM	O-Ring, Seat - 70D	6
	◆ 46206	EPDM	O-Ring, Seat - 70D	6
164	43722	S	Seat	6
166	43721	S	Valve	6
167	43751	S	Spring	6
168	44564	PVDF	Retainer, Spring	6
172	17617	NBR	O-Ring, Valve Plug - 90D	6
	11691	FPM	O-Ring, Valve Plug - 90D	6
	◆ 46207	EPDM	O-Ring, Valve Plug - 70D	6
174	43851	BBCP	Plug, Valve	6
	43850	BB	Plug, Valve	6
185	45975	NAB	Head, Manifold	1
187	126545	STCP R	Stud (M10x45)	4
192	126231	STCP R	Lockwasher (M10)	4
194	126522	STCP R	Nut, Hex (M10)	4
250	30764	NY	Protector, Shaft w/2 Screws	1
255	30264	STZP	Mount, Direct	1
260	30613	STZP R	Mount, Rail Assy - A (30635,30903,30921,30912)	1
	990550	STZP R	Mount, Rail (Required on Diesel/Gas)	1
269	30206	F	Pulley (10") [See Tech Bulletin 003]	1
274	30059	STL	Hub, "H" (M30) (Keyway M8) [See Tech Bulletin 003]	1
283	34334	—	Kit, Oil Drain (3/8"x24")	1
299	814561	BB	Head, Complete	1
300	30798	NBR*	Kit, Seal (Incls: 97,100,106,121,127)	1
	31033	FPM	Kit, Seal (Incls: 97,100,106,121,127)	1
	◆ 33919	EPDM*	Kit, Seal (Incls: 97,100,106,121,127)	1

EXPLODED VIEW

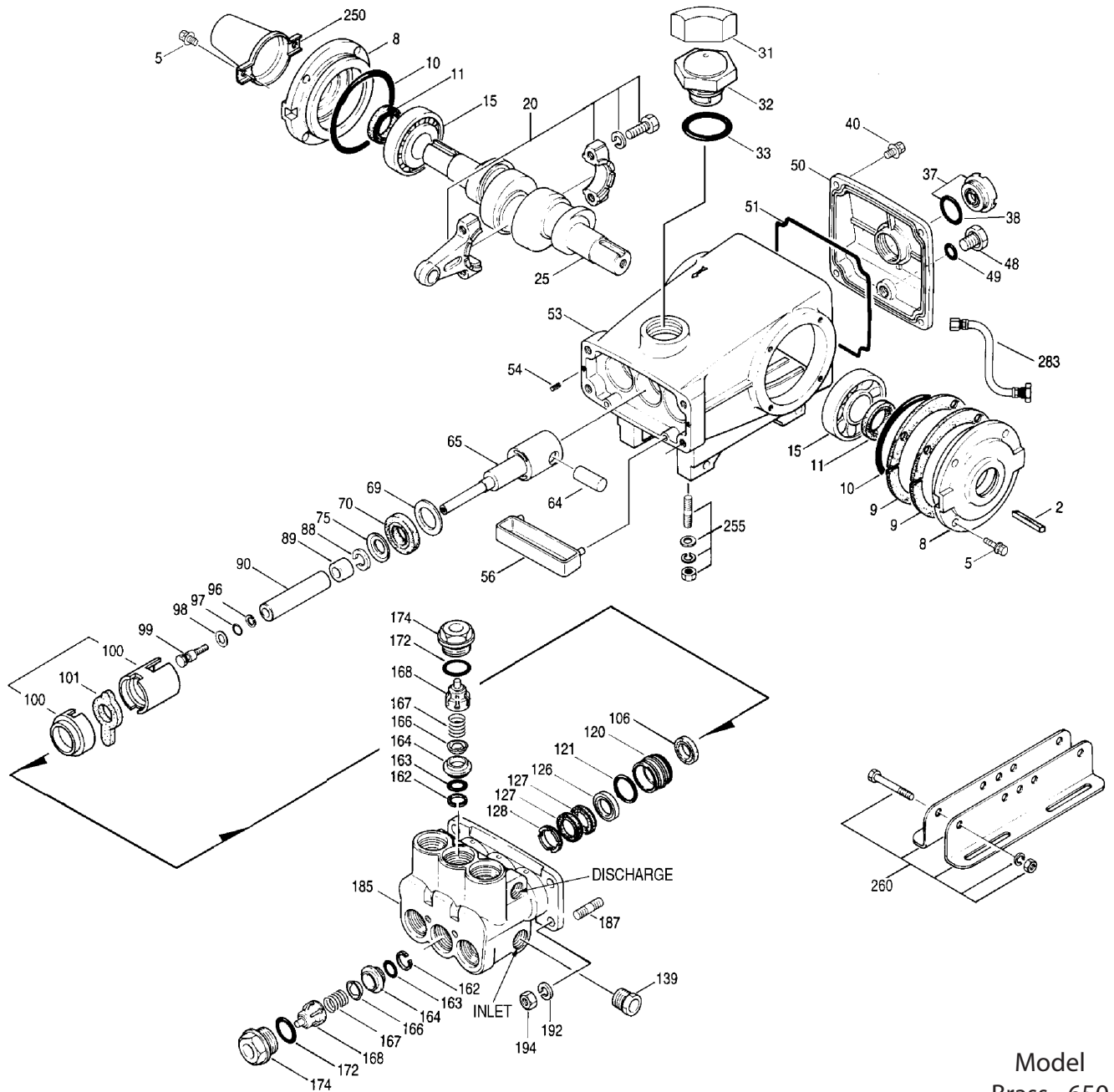

Model
Brass - 650
July 2012

ITEM	PART NUMBER	MATL	DESCRIPTION	QTY
310	30820	NBR	Kit, Valve (Incls: 162,163,164,166,167,168,172)	2
	31263	FPM	Kit, Valve (Incls: 162,163,164,166,167,168,172)	2
	◆ 31259	EPDM	Kit, Valve (Incls: 162,163,164,166,167,168,172)	2
	350	30696	STZP	Plier, Reverse
351	43523	STZP	Tool, Seal Case Removal	1
	33006	STZP	Socket, Seal Case 1/2" Drive	1
352	44050	STZP	Tool, Oil Gauge Removal	1
	6107	—	Oil, Bottle (21 oz.) ISO 68 Hydraulic	2
	6575	—	(Fill to specified crankcase capacity prior to start-up) Plunger Pump Service DVD	1

Italics are optional items. ◆ Silicone oil/grease required.

[] Date of latest production change. R Components comply with RoHS Directive.

See Tech Bulletins 002, 003, 024, 027, 035, 036, 043, 045, 048, 049, 052, 053, 062, 074, 077, 083 and 098 for additional information.

MATERIAL CODES (Not Part of Part Number): ABS=ABS Plastic AL=Aluminum BB=Brass BBCP=Brass/Chrome Plated CC=Ceramic CM=Chrome-Moly
 CU=Copper EPDM=Ethylene Propylene Diene Monomer F=Cast Iron FBR=Fiber FCM=Forged Chrome-Moly FPM=Fluorocarbon NAB=Nickel Aluminum Bronze
 NBR=Medium Nitrile (Buna-N) NY=Nylon PE=Polyethylene POP=Polypropylene PTFE=Pure Polytetrafluoroethylene PVDF=Polyvinylidene Fluoride S=304SS
 SFTB=Special Blend PTFE Black SHS=304SS/High Strength STCP=Steel/Chrome Plated STG=Special Blend PTFE White STL=Steel STZP=Steel/Zinc Plated
 SZZ=304SS/Zamak TNM=Special High Strength

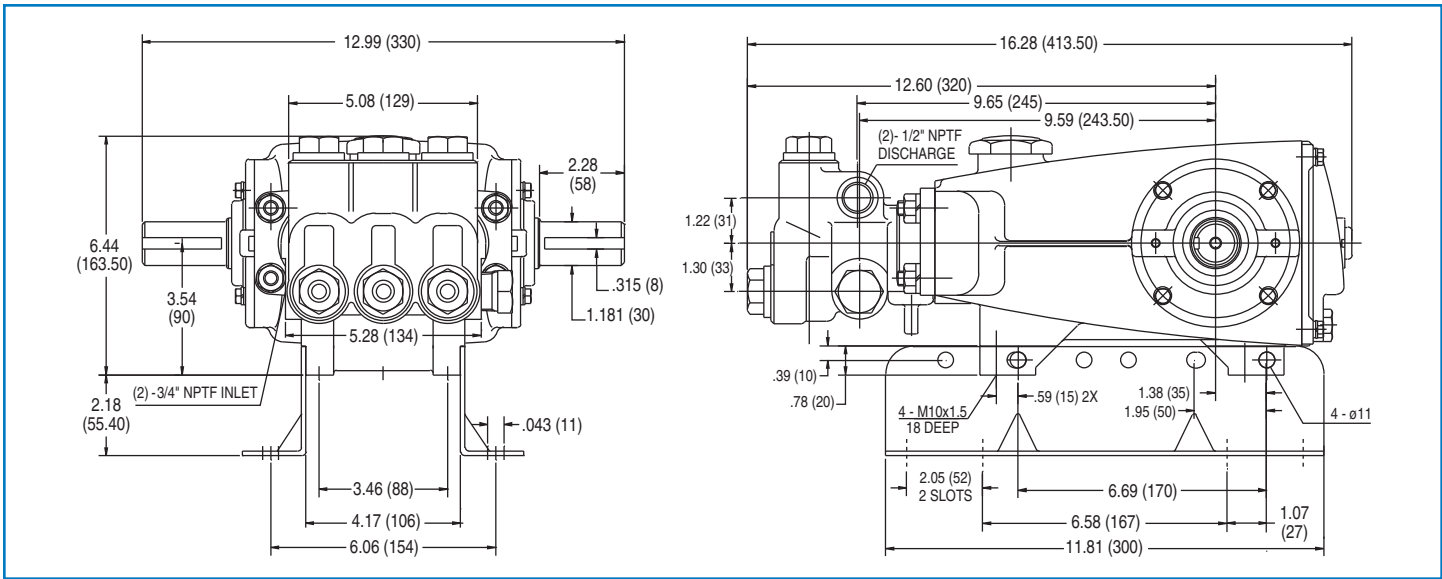

Model 650

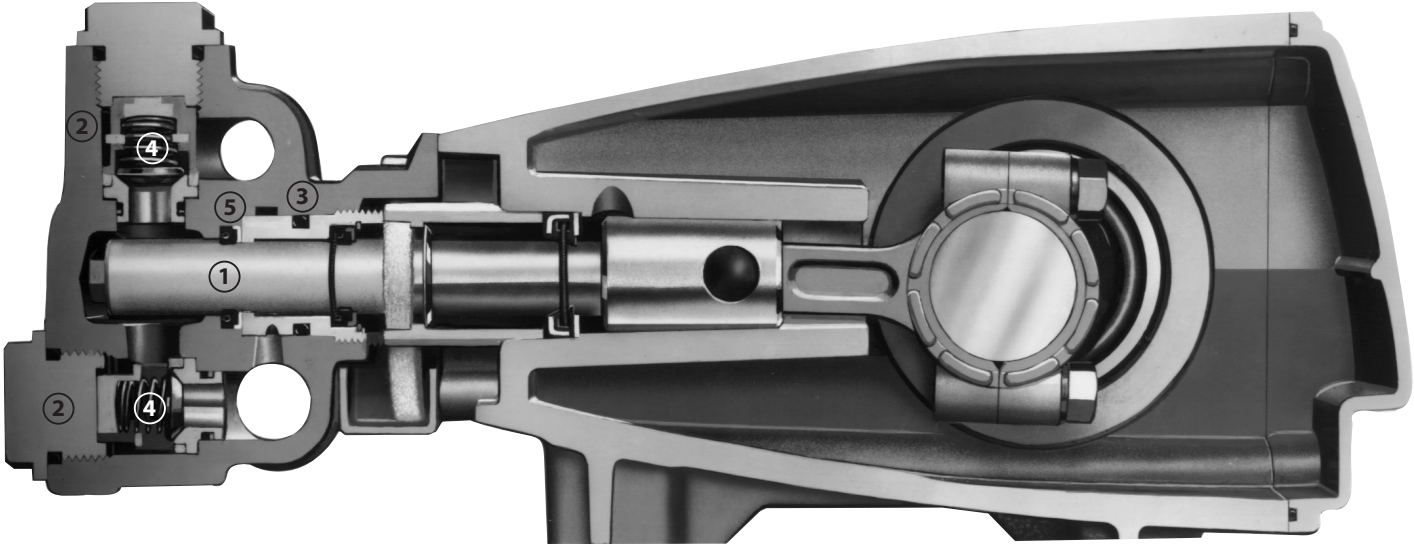

- 1 Special concentric, high density, polished, solid ceramic **plungers** provide a true wear surface and extended seal life.
- 2 **Manifolds** are a high tensile strength bronze for long term, continuous duty and corrosion resistance.
- 3 100% wet **seal** design adds to service life by allowing pumped liquids to cool and lubricate on both sides.
- 4 Stainless steel **valves, seats and springs** provide corrosion-resistance, ultimate seating and extended life.
- 5 Specially formulated, Cat Pump exclusive, **V-Packing** offer unmatched performance and seal life.



CAT PUMPS
 1681 - 94TH LANE N.E. MINNEAPOLIS, MN 55449-4324
 PHONE (763) 780-5440 — FAX (763) 780-2958
 e-mail: techsupport@catpumps.com
 www.catpumps.com