



7 Frame Plunger Pump

Model

70

Gearbox

Model

70G1

FEATURES

- Triplex design delivers high efficiency and low pulsation.
- Durable V-Packings are lubricated and cooled by the liquid being pumped.
- Pre-set Lo-Pressure Seals provide secondary protection against external leaks and require no packing adjustment.
- Special high-density, polished, concentric plungers provide a true wear surface and extended seal life.

SPECIFICATIONS

U.S. Measure

Metric Measure

MODELS 70, 70G1

Flow	4.5 gpm	(17 lpm)
Pressure Range.....	100 to 5000 psi	(7 to 345 bar)
Inlet Pressure Range.....	Flooded to 60 psi	(Flooded to 4 bar)
RPM.....	1700 rpm	(1700 rpm)
Engine RPM (70G1).....	3465 rpm	(3465 rpm)
Bore	0.551"	(14 mm)
Stroke.....	0.945"	(24 mm)
Crankcase Capacity.....	.25 oz.	(0.75 l)
Maximum Liquid Temperature	160°F	(71°C)
Above 130°F call CAT PUMPS for inlet conditions and elastomer recommendations.		
Inlet Ports (2).....	1/2" NPTF	(1/2" NPTF)
Discharge Ports (2).....	3/8" NPTF	(3/8" NPTF)
Shaft Diameter - Single End.....	0.945"	(24 mm)
Weight w/o Gearbox	36.2 lbs.	(16.4 kg)
Dimensions.....	14.21 x 9.21 x 6.69"	(361 x 234 x 170 mm)
Dimensions w/Gearbox ...	14.21 x 10.75 x 8.19"	(361 x 273 x 208 mm)
See Gearbox Data Sheet for additional information.		

ELECTRIC HORSEPOWER REQUIREMENTS

FLOW		PRESSURE				MOTOR PULLEY SIZE	
		psi 3000	psi 3500	psi 4000	psi 5000	Using 1725 RPM Motor & Std. Pump Pulley O.D.	
U.S. gpm	lpm	bar 210	bar 245	bar 275	bar 345	rpm	Pulley O.D.
4.0	15	8.2	9.6	11.0	13.7	1511	8.5
4.5	17	9.3	10.8	12.3	15.4	1700	9.5
4.5	17	9.3	10.8	12.3	15.4	1700	Gearbox

DETERMINING	Rated gpm	=	"Desired" gpm
THE PUMP R.P.M.	Rated rpm	=	"Desired" rpm
DETERMINING	gpm x psi	=	Electric Brake
THE REQUIRED H.P.	1460	=	H. P. Required
DETERMINING	Motor Pulley O.D.	=	Pump Pulley O.D.
MOTOR PULLEY SIZE	Pump rpm	=	Motor rpm

⚠ CAUTIONS AND WARNINGS

All High Pressure Systems require a primary pressure regulating device (i.e. regulator, unloader) and a secondary pressure relief device (i.e. pop-off valve, relief valve). Failure to install such relief devices could result in personal injury or damage to pump or property. CAT PUMPS does not assume any liability or responsibility for the operation of a customer's high pressure system.

Read all CAUTIONS and WARNINGS before commencing service or operation of any high pressure system. The CAUTIONS and WARNINGS are included in each service manual and with each Accessory Data sheet. CAUTIONS and WARNINGS can also be viewed online at www.catpumps.com/cautions-warnings or can be requested directly from CAT PUMPS.

WARRANTY

View the Limited Warranty on-line at www.catpumps.com/warranty.

See complete Drive Packages [Incls: Pulleys, Belts, Hubs, Key] Tech Bulletin 003. Refer to pump **Service Manual** for repair procedure and additional technical information.

PARTS LIST

ITEM	P/N	MATL	DESCRIPTION	QTY
2	30067	STL	Key (M8x7.5x25)	1
5	92519	STZP	Screw, HHC Sems (M6x16)	8
	125824	STCP R	Screw, HHC Sems (M6x16)	8
8	43466	AL	Cover, Bearing	1
9	815280	FBR	Shim, Split, 2 Pc.	1
10	12393	NBR	O-Ring, Bearing Cover	2
11	43222	NBR	Seal, Oil, Crankshaft - 70D	1
15	43221	STL	Bearing, Roller	2
20	48863	TNM	Rod, Connecting [6/02]	3
25	119234	FCM	Crankshaft, Single End	1
	46554	FCM	Crankshaft, Single End (Gearbox Only)	1
30	44967	AL	Cover, Blind Bearing	1
31	828710	—	Protector, Oil Cap w/Foam Gasket	1
32	44666	RTP	Cap, Oil Filler, Domed	1
33	14177	NBR	O-Ring, Oil Filler Cap - 70D	1
37	92241	—	Gauge, Oil, Bubble w/Gasket - 80D	1
38	44428	NBR	Gasket, Flat, Oil Gauge - 80D	1
40	92520	STZP	Screw, HHC Sems (M6x20)	4
	126541	STCP R	Screw, HHC Sems (M6x20)	4
48	25625	STCP	Plug, Drain (1/4"x19BSP)	1
49	23170	NBR	O-Ring, Drain Plug - 70D	1
50	127701	AL	Cover, Rear	1
51	44836	NBR	O-Ring, Rear Cover - 70D	1
53	127698	AL	Crankcase w/Guide Pins	1
56	43240	POP	Pan, Oil	1
64	43237	CM	Pin, Crosshead	3
65	48913	SHS	Rod, Plunger, Short [5/02]	3
69	126589	STCP R	Washer, Oil Seal	3
70	43228	NBR	Seal, Oil, Crankcase	3
75	43328	S	Slinger, Barrier	3
88	45697	S	Washer, Keyhole (M18x10)	3
89	46556	BB	Spacer	3
90	45890	CC	Plunger (M14x72)	3
95	126559	STCP R	Stud, Plunger Retainer (M6x70)	3
96	43235	PTFE	Back-up-Ring, Plunger Retainer	3
97	17399	NBR	O-Ring, Plunger Retainer - 80D	3
	14160	FPM	O-Ring, Plunger Retainer - 80D	3
98	45891	CU	Gasket, Plunger Retainer	3
99	46504	S	Retainer, Plunger (M6)	3
100	45689	PVDF	Retainer, Seal, 2-Pc (See Tech Bulletin 105)	3
101	43571	—	Wick, Long Tab	3
106	45188	NBR	Seal, LPS w/S-Spg	3
	701790	SFTA	Seal, LPS w/NIH-Spg	3
120	46566	BB	Case, Seal	3
121	20285	NBR	O-Ring, Seal Case - 70D	3
	11693	FPM	O-Ring, Seal Case	3
126	45896	BB	Adapter, Female	3
127	45895	SNG	V-Packing	9
	48300	STG	V-Packing	9
128	46567	BB	Adapter, Male	3
139	43448	BB	Plug, Inlet Manifold (1/2" NPTM)	1
162	20937	PTFE	Back-up-Ring, Spiral, Seat	6
163	17547	NBR	O-Ring, Seat - 85D	6
	11685	FPM	O-Ring, Seat - 85D	6
164	46560	S	Seat	6
166	46562	S	Valve	6
167	43750	S	Spring	6
168	44565	PVDF	Retainer, Spring	6
172	145952	NBR	O-Ring, Valve Plug -70D	6
	31932	FPM	O-Ring, Valve Plug -75D	6
173	46692	PTFE	Back-up-Ring, Spiral, Valve Plug	6
174	46581	BB	Plug, Valve, Extended	6
185	46558	FBB	Head, Manifold (M10)	1
187	46868	S	Stud, Manifold (M10x35)	4
194	126567	STCP R	Nut, Flanged (M10)	4
255	30243	STZP	Mount, Direct	1
260	30645	STZP R	Assy, Angle Rail A	1
	30611	STZP R	Assy, Angle Rail B	1
265	30660	—	Mount Assy (Incls: 30645, 33000, 30206, 43256, 30067)	1
269	30206	F	Pulley (10") AB [See Tech Bulletin 003]	1
274	33000	STL	Hub (M24), H Series [See Tech Bulletin 003]	1
283	34334	—	Kit, Oil Drain (3/8"x 24") (See individual Data Sheet)	1
	76334	—	Kit, Oil Indicator (3/8"x 24") (See individual Data Sheet)	1

EXPLODED VIEW

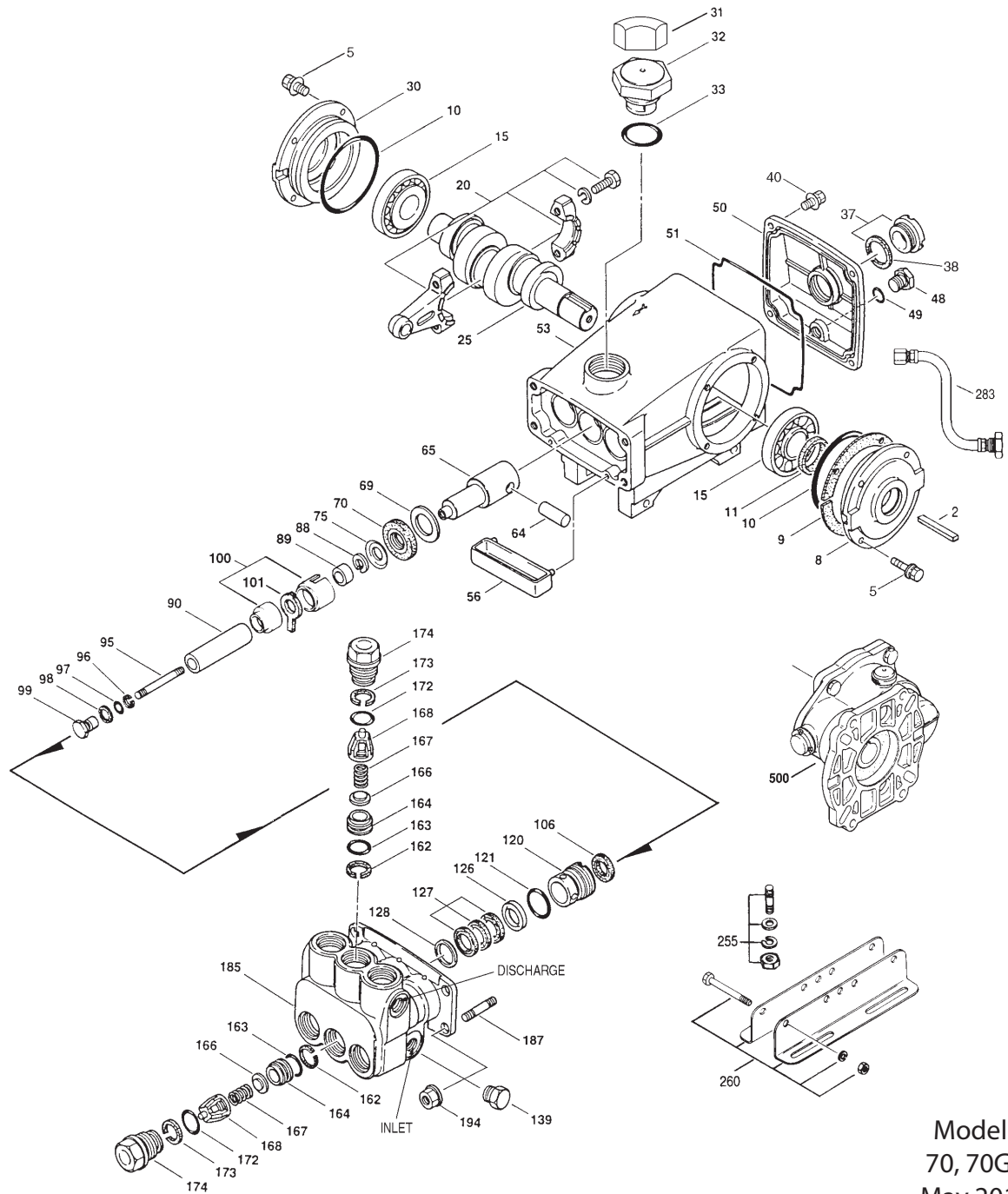

Models
70, 70G1
May 2012

ITEM	P/N	MATL	DESCRIPTION	QTY
299	814840	FBB	Head, Complete	1
300	33799	NBR	Kit, Seal (Incls: 97,101,106,121,127)	1
	31799	FPM	Kit, Seal (Incls: 97,101,106,121,127)	1
310	33822	NBR	Kit, Valve (Incls: 162,163,164,166,167,168,172,173)	2
	31722	FPM	Kit, Valve (Incls: 162,163,164,166,167,168,172,173)	2
350	30696	STZP	Pliers, Reverse	1
351	43257	STZP	Tool, Seal Case Removal	1
352	44050	STZP	Tool, Oil Gauge Removal	1
500	8071	—	Gearbox, 1" (See 8051-8078 Data Sheet)	1
—	6107	—	Oil, Bottle (21 oz.) ISO 68 Hydraulic (Fill to specified crankcase capacity prior to start-up)	1

Italics are optional items. [] Date of latest production change. R Components comply with RoHS Directive.

Refer to Tech Bulletins 002, 003, 024, 036, 043, 051, 054, 061, 064, 067, 074, 077, 083 and 105 for additional information.

MATERIAL CODES (Not Part of Part Number): AL=Aluminum BB=Brass CC=Ceramic CM=Chrome-Moly CU=Copper F=Cast Iron FBB=Forged Brass FBR=Fiber
FCM=Forged Chrome-moly FPM=Fluorocarbon NBR=Medium Nitrile (Buna-N) POP=Polypropylene PTFE=Pure Polytetrafluoroethylene
PVDF=Polyvinylidene Fluoride RTP=Reinforced Composite S=304SS SFTA=Special Blend PTFE Tan SHS=304SS/High Strength SNG=Special Blend (Buna)
STG=Special Blend PTFE White STL=Steel STCP=Steel/Chrome Plated STZP=Steel/Zinc Plated TNM=Special High Strength

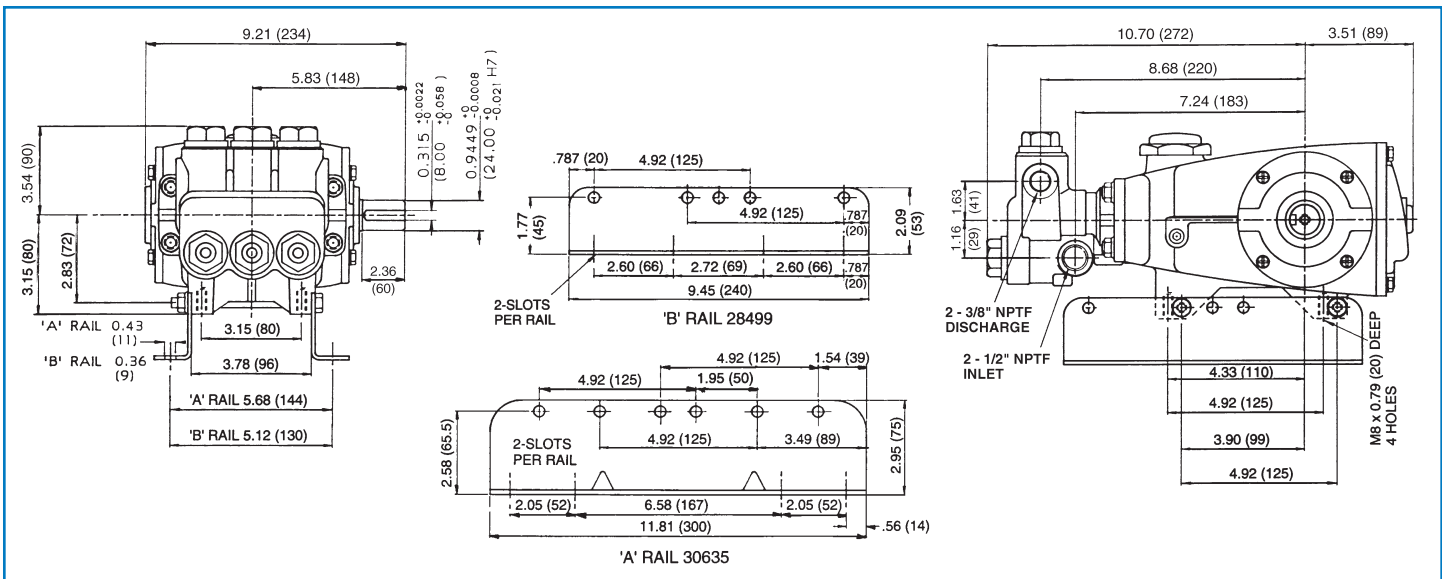

Models 70, 70G1

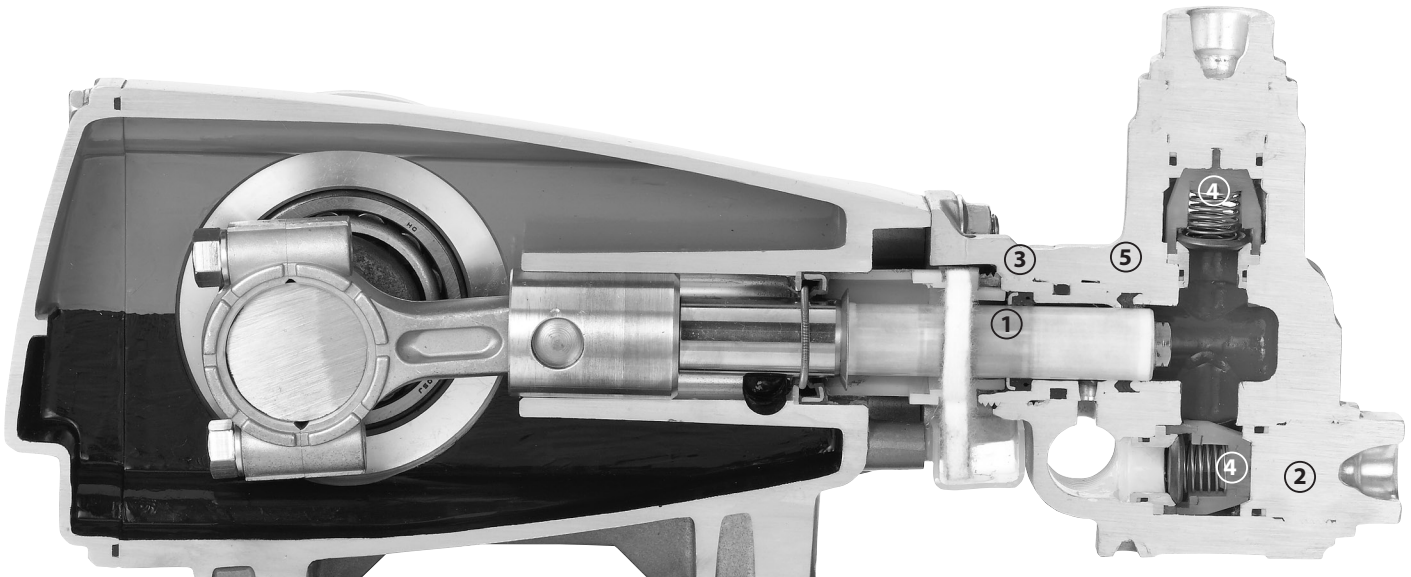

- 1 Special concentric, high-density, polished, solid ceramic **plungers** provide a true wear surface and extended seal life.
- 2 **Manifolds** are a high tensile strength forged brass for long term, continuous duty.
- 3 100% wet **seal** design adds to service life by allowing pumped liquids to cool and lubricate on both sides.
- 4 Stainless steel **valves, seats and springs** provide corrosion-resistance, ultimate seating and extended life.
- 5 Specially formulated, Cat Pump exclusive, **V-Packings** offer unmatched performance and seal life.



CAT PUMPS
 1681 - 94TH LANE N.E. MINNEAPOLIS, MN 55449-4324
 PHONE (763) 780-5440 — FAX (763) 780-2958
 e-mail: techsupport@catpumps.com
 www.catpumps.com